



F·S·A·R·G  
The Faversham Society  
Archaeological Research Group

Community  
Archaeology

## Understanding Ospringe

### Report for Keyhole Pit 81 4 & 5 Pettits Row, Ospringe Road, Faversham

Grid Reference TR 00690 61054



**Fully excavated cistern**

## 1. Introduction

This investigation came about as a result of a chance discovery by the home owner while removing an old garden path. In the process, a buried circular brick structure was discovered. FSARG were invited to try and throw some light on what was believed to be (from an initial evaluation) part of a possible underground water system. We have come across these before in Faversham and were therefore very interested<sup>1</sup>.

Pettits Row is tucked away behind numbers 98 – 108 Ospringe Road (to the North) and consists of five terraced Victorian cottages. Records of the occupants first appear on the 1871 Census. From their occupations – Powder Works labourer, Cartridge Maker, Cartridge Packer etc. - it would appear that the cottages were closely associated with gun powder manufacturing, and probably date from the mid-Victorian period.

Fig 1a and Fig 1b show Pettits Row in 1897<sup>2</sup>, and a current Google Earth view.

## 2. Location of Pit

A number of boundary changes have taken place recently and the structure was discovered in an area that was previously part of the rear garden of number 98 Ospringe Road.

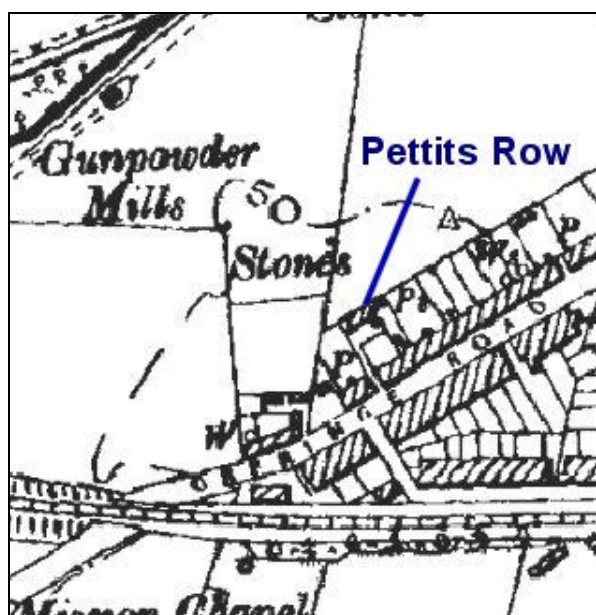

Fig 1a.

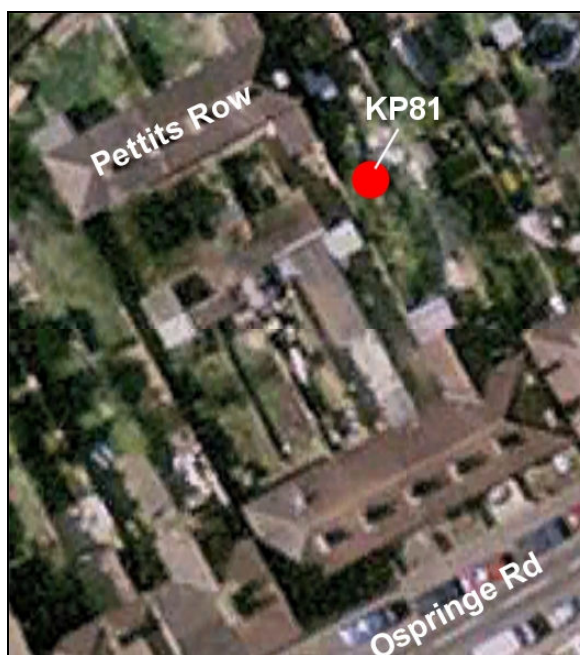

Fig 1b.

This was a slightly unusual excavation since the area had already been partly cleared (approx. 2.8m x 2.8m). As such, the excavation area had already been defined for us. This was situated to the north east of Number 5's original flint boundary wall.

## 3. The Procedures

The initially cleared area that showed a number of partly exposed bricks was expanded until a complete circular structure was revealed. This was achieved by expanding the excavation area to approx. 3.5m x 3.5m. This necessitated the partial removal of a recently laid brick path, together with part of the former garden path. In

<sup>1</sup> See Reports for K48 and for Davington Priory on FSARG website [www.community-archaeology.org.uk](http://www.community-archaeology.org.uk)

<sup>2</sup> OS Landmark Edition 2 map (1897)

addition to the circular feature, there were also signs of further brickwork leading away in a southerly direction towards the original flint boundary wall, so this area was also cleared.

The excavation was carried out contextually, removing and recording each layer in succession. Where appropriate, the spoil was sieved and / or metal detected. All features and finds were carefully recorded. However, since the garden was to be landscaped once our excavation was completed, there was no requirement to backfill.

#### 4. The Findings

As more of the brick feature became exposed, the area was expanded in order to see the complete picture. Fig 2 shows the start of the excavation where most of the first context had already been removed by the owner Darius.

This first context (01) was a highly disturbed layer of greyish brown ashy soil containing a mixture of CBM (ceramic building material), pottery, glass, clay tobacco pipe stems, animal bone, slate, iron, pins, plastic, shell, and coal – all the typical materials found in urban garden topsoil. Due to the nature of the layer, only a representative sample of materials was assessed. No sieving was carried out.

The context extended 10cm below the level that our excavation had started. Once this layer was removed, the outline of the brick structure became clear (Fig 3). It consisted of a main outer circular structure with another square (rendered) brick feature in the centre. Protruding vertically from the centre was a lead pipe. In addition, to the south side was a channel consisting of 2 rows of bricks with a mortared base (Fig 4). A brick lay at the end of the channel (as can be seen in Fig 2). On the inside face of the circular brick structure a rendered surface was clearly visible.

Mortar was present on the surface of the bricks and there were gaps in several places, suggesting that the structure would have originally been higher, and that one or more brick courses have been removed.

The channel to the south of the structure dropped away as it headed south. This suggested that this could have been an overflow runoff.



**Fig 2. Work begins to reveal the structure.**

Measurements were taken of the features which had an outer diameter of 2.62m, inner diameter of 2.12m and the square central brick feature was 0.36m x 0.36m. In order to excavate the next context (02) it was decided that a quadrant would be removed (Fig 5) in order to look at the section (Fig 6). Context (02) was a well compacted, well sorted chalk layer some 0.55m thick containing a small amount of varying sized flints. There were very few inclusions consisting of glass, slate, pottery, charcoal, iron, clay pipe stem and fish bone.

Interspersed within this chalk layer were lenses of dark brown soil (as can be seen in Fig 6). Sieving of this layer was initially carried out, but this was very unproductive with no worthwhile dateable materials being found, so was subsequently stopped.

Once this quadrant of (02) was removed, what became apparent was the high build quality of the structure. This



**Fig 3. With the first context removed the complete structure was revealed.**



**Fig 4. Channel running away southward towards the boundary wall of number 5 Pettits Row.**

was far superior to that of the washhouses that were at the end of the gardens of Pettits Row. It certainly looked more industrial than domestic.



**Fig 5. (02) Quadrant being removed.**



**Fig 6. Section view of (02) looking east.**



**Fig 7. (02) Quadrant excavated.**

The layer beneath (02) – context (03) – was the next to be excavated. This was a 13cm deep layer of dark brown soft soil with inclusions of bone and pieces of render. Once this layer was removed, it exposed the base of the structure. This had the same high quality render as the inside of the outer wall. Once cleaned, a hole through the base was evident – almost certainly done deliberately once the structure fell out of use (Fig 8). The base sloped downwards towards the central brick pillar dropping some 6cm. Our attention was now given to the lead pipe protruding vertically from the centre of the pillar. By pushing a rod down the centre, a bend could be detected towards the north-west. It was decided to extend the excavation of (02) and (03) on the north-west side to try and locate the other end of the pipe (Fig 9).



**Fig 8. The base of the structure showing the rendered base with the hole.**

The pipe emerged on the north-west side some 18cm down from the top. The lead pipe had been cut off flush with the surface (Fig 10), but some staining on the surface of the pillar and rendering marks showed that the pipe ran vertically down the pillar to a lower level.

Over on the north-west side was a second lead pipe (Fig 11). This pipe emerged through the wall and continued north-westerly under the garden path towards the bottom of the garden.

The owner confirmed that there was an out-



**Fig 9. Revealing the lead pipe.**



**Fig 10. Lead pipe cut flush.**

building situated there which was tiled with plain white glazed ceramic tiles. He also recalls there being lead pipe work inside.

There were two other areas that needed focusing on – the channel leading south from the structure and whether there was any other pipework associated with it. Firstly, the channel was followed and exposed again on the north-side of the flint boundary wall (Fig 12). The channel was similar to those found during the Davington Priory work carried out in 2005 (Fig 13). The channel was then chased at the south side of the flint wall and found to terminate in an earlier drainage complex. There were various traps and a gully visible from one of the wash houses (Fig 14) that appeared just below the ground surface.



**Fig 11. Second pipe north-west from the structure under the garden path.**

In order to establish the existence of any other pipework, the remaining material was removed from the inside of the circular structure.



**Fig 12. Channel going through flint wall.**



**Fig 13. Similar constructed channels found at Davington Priory in 2005.<sup>3</sup>**



**Fig 14. Showing the gully and drain complex.**

<sup>3</sup> Report for Davington Priory op. cit. FSARG/OSP11/KP81

There were no further pipes, however another hole in the base was found which was large enough to establish the construction of the base - which was a single brick thick with rendering on top.

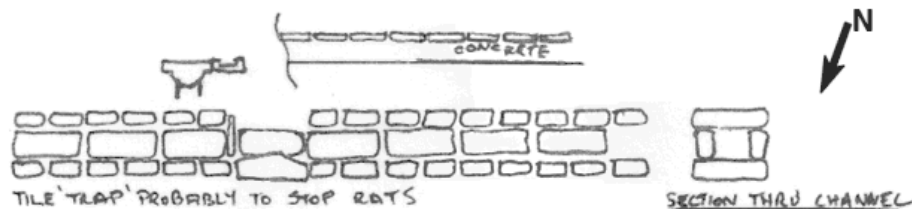

The 'overflow channel', which exited the main structure in a southerly direction, was excavated approx. 2.0m from the main structure in an attempt to discover if it flowed into a soak-away.

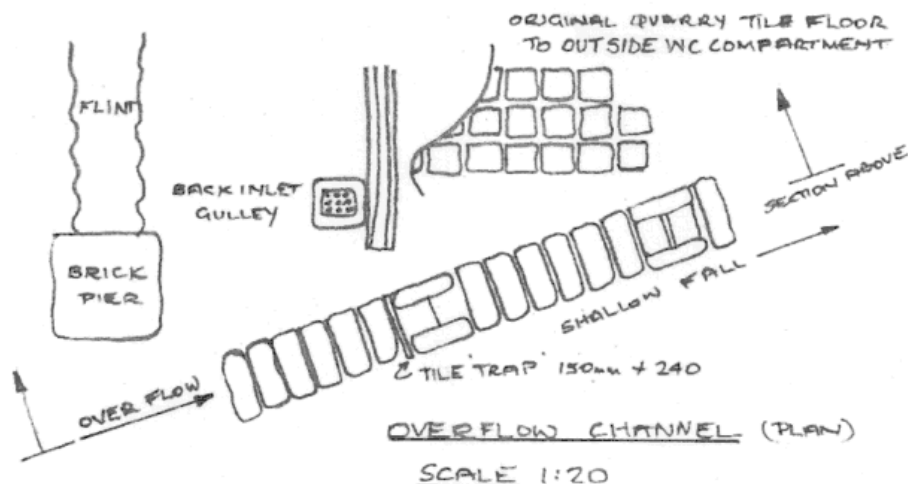

**Details of the overflow channel**

At a point 22cm below the adjacent quarry tiled floor surface of the former outside WC compartment the top surface of the covering brick course of the 'overflow channel' was located. An area

1m in length was excavated which revealed a feature lacking the covering brick course as detailed in the drawing on the right. The feature showed a tile built vertically into the channel. This is probably a form of 'trap' designed to prevent rat access to the possible soak-away. The covering two bricks were probably left unmortared to allow the trap to be cleaned. The distance from the main structure to the 'tile trap' was 2.9m.

The bed of the channel showed a double sloped cement feature as detailed in the drawing. Though the fall of the channel is very shallow, this feature may have been designed to maintain a low level of water within the channel to prevent mouse access. The channel continued under the existing shed, which prevented further excavation. The continuation was probed to a distance of 1m from the original 'trap' at which point it was obstructed - possibly by another 'trap'.

Situated 15.5cm above the 'overflow channel' was a salt-glazed back inlet gulley and concrete channel associated with the quarry tiled floor.

## 5. Interpretation

Our initial evaluation was that this was a water storage vessel (cistern) and I think it's fairly safe to say this has been confirmed by our excavations. The main storage vessel (which would have originally had a higher outer wall) was some 2.6m across with an internal diameter of 2.12m and has a (remaining) depth of 0.63m. This would have given an approximate volume of 2.14m<sup>3</sup> which equates to 2,142 litres (or 471 gallons). The central pillar with one of the lead pipes leading up from the centre is clearly a water outlet. The pipe originally continued down to a lower level within the cistern (so that water could still be drawn off when the level was low). A second outlet fed down the garden probably to the outbuilding with the white glazed tiles.

The association of the people who dwelled in these cottages with the Gun Powder works suggests that the water may have been used for an industrial process as well as perhaps domestic use. There were probably 2 separate hand pumps to draw water up.

The channel running away from the cistern is almost certainly an overflow arrangement whereby excess water would flow into the drain complex.

A piece of the jigsaw that we have not resolved was how the water entered the storage vessel. Since there was no other pipework where the water could have entered, it's probable that the water was fed into the cistern at a level higher above that which currently remains. When the upper brick courses were removed, the inlet would have also been removed.

The OS Landmark Edition 2 map (1897) shown in Fig 1a shows a 'P' where the cistern was found. Unfortunately, Ordnance Survey has not been able to confirm that the 'P' signifies *Pump* on this particular map edition. However *Pump* is one of the possibilities that are listed, and we are confident that it does indeed mean a pump in this instance.

## 6. Final Comments

The dating of this structure is tricky... In a more usual excavation where layers (or contexts) are built up through events in time, in this case, the materials that were excavated were *inside* the structure (as a backfill) and could have come from literally anywhere, so these are of little use for dating.

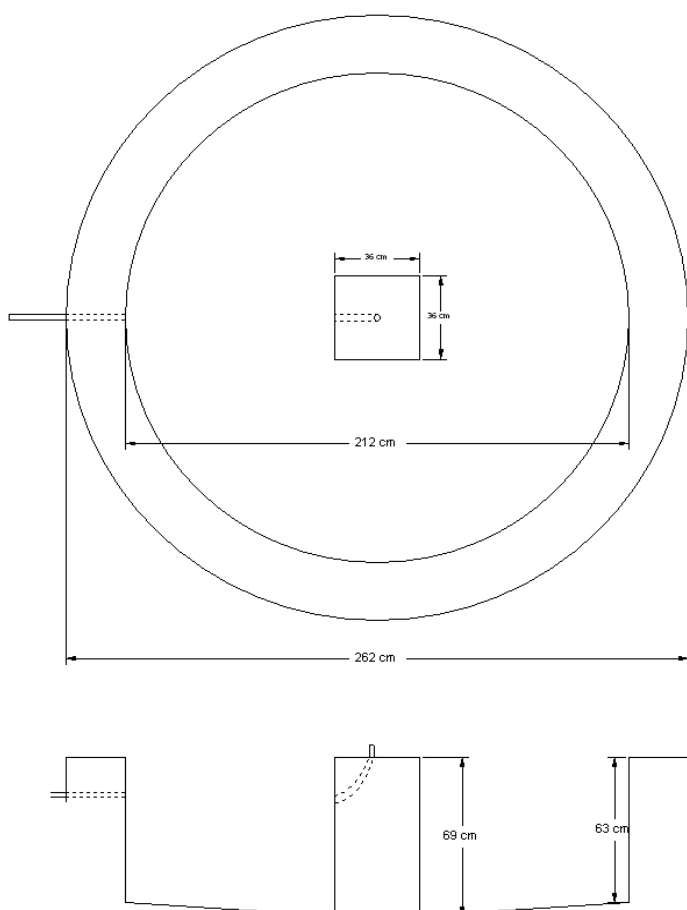

**Fully excavated cistern**

An alternative is to date it from the *design*, but as yet we have not been able to find any definitive information on water cisterns and domestic water management structures in the pre-pipes and post wells set up. Therefore the only dating evidence comes from the brick and mortar itself.

The mortar is a lime mortar, used in the post medieval and early modern period. The bricks themselves have dimensions<sup>4</sup> and colour closer to those of the 18th rather than the mid 19th century ( see figs Finally and perhaps more definitively, these bricks do not have frogs, the scoop on one side which is always present in modern bricks. Frogging first came in in the early 18th century, possibly as a response to the brick taxes of the late 18th century when bricks were taxed by weight.<sup>5</sup> Although frogging may have taken a few years to reach Faversham, the bricks do seem to date this structure to well before the building of the houses. Thus the tank is either associated with an earlier property (and we have no evidence for such a property on the early maps<sup>6</sup>) or with the nearby gunpowder industry or windmill<sup>7</sup>.

## 7. Acknowledgements

We would like to say a big thank you to the home owners Darius and Debbie Coombs for giving us the opportunity to excavate an interesting feature that will contribute to our knowledge of the area. We were looked after extremely well with ample refreshments, and very much appreciated Darius's hard work while we were removing the bulk of the soil.

Mike Tillman  
FSARG

28<sup>th</sup> November 2011

---

<sup>4</sup> Walker, B 2007 *The History of Bricks* on [www.propertydrum.com](http://www.propertydrum.com)

<sup>5</sup> Walker B op.cit.

<sup>6</sup> e.g. OS 1865 Sheet XXXIV Scale 1: 2500

<sup>7</sup> Viner, J 1982 *Lost windmills of Faversham* Faversham Paper No 21 Faversham Society: Faversham  
FSARG/OSP11/KP81